

Smart Cabinet

User Manual

Contents

| | |
|---|-----------|
| Introduction | 4 |
| Warranty | 4 |
| Product Warranty Period | 4 |
| Conditions to exercise the warranty | 5 |
| How to exercise the warranty? | 5 |
| Warranty exclusions | 6 |
| Limitations and liability exemptions | 7 |
| Conformity | 8 |
| Specifications | 9 |
| | |
| Safety and compliance | 11 |
| General information | 11 |
| Hazards | 11 |
| Electrical safety | 12 |
| Heating safety | 12 |
| Mechanical safety | 12 |
| Proper area to install the system | 13 |
| Moving the device | 14 |
| | |
| Installation | 15 |
| What is in the box? | 15 |
| Unboxing | 16 |
| Diagram | 17 |
| Set up | 19 |
| Remove protections | 19 |
| Full system setup | 19 |
| | |
| Getting started | 21 |
| Store material spools inside the dehumidifier | 21 |
| Using BCN3D Spool Cartridges | 22 |
| Without BCN3D Spool Cartridges | 24 |
| Store tools in the maintenance tray | 25 |
| Store consumables in storage area | 26 |
| | |
| Operation | 27 |
| Material handling | 27 |
| Load filament | 27 |
| Using BCN3D Spool Cartridges | 27 |
| Without BCN3D Spool Cartridges | 28 |
| Unload filament | 29 |
| Using BCN3D Spool Cartridges | 29 |
| Without BCN3D Spool Cartridges | 30 |
| Humidity control | 31 |
| Power protection | 32 |

| | |
|--|-----------|
| Maintenance | 33 |
| General maintenance | 33 |
| Firmware upgrade | 34 |
| Troubleshooting | 35 |
| Error message | 35 |
| BCN3D Technical Assistance Services | 36 |
| Technical Assistance | 36 |
| Email | 36 |
| Terms and Conditions | 37 |
| Overall Vision | 37 |
| Return policy | 37 |

Introduction

Warranty

Technical Support

For any questions or problems with BCN3D Products, please contact us at:

Carrer de Miquel Servet, 18
08850 Gavà, Barcelona (España)
URL: <http://www.bcn3d.com/support-contact/>
Tel: +34 935 95 43 43

BARCELONA THREE DIMENSIONAL
PRINTERS, S.L.
VAT: ESB67235069
Manufactured in Spain

List of Consumable components

This document lists the Consumable components that, due to their natural deterioration, are excluded from the Warranty: **BCN3D Spool Cartridge, Teflon tubes, Filament spools, Printed parts.**

BARCELONA THREE DIMENSIONAL PRINTERS, S.L. provides this Warranty to the consumers of the BCN3D brand products included in the sales package ("Product").

This Warranty will be valid only in the country in which the sale of the Products has been made. BARCELONA THREE DIMENSIONAL PRINTERS, S.L. hereby guarantee that, within the warranty period, BARCELONA THREE DIMENSIONAL PRINTERS, S.L. or an authorized service company will correct, within a reasonable period of time, the defects of materials or manufacturing detected in the Products, according to the clauses set out below.

All the products purchased at BCN3D Technologies are covered by the **Law 23/2003** of July 10 of Warranties on the Sale of Consumer Goods (consolidated in Royal Legislative Decree 1/2007). Also covered by the **Directive 99/44 /CE** of the European Parliament and of the Council of 25 May 1999 on certain aspects of the sale and warranties of consumer goods, as amended by the Directive **2011/83/UE** of the European Parliament European Parliament and the Council of 25 October 2011 on the rights of consumers.

The products acquired to integrate them in a productive or commercial process, will have a warranty period of not less than six months as provided in the **articles 1484 to 1491 of the Civil Code** for hidden defects or defects.

Product Warranty Period

As previously stated, all products purchased directly from BCN3D Technologies will have a 12-month warranty for all those purchases made within the European Union, and 12 months for the rest of the countries. The warranty will come into force from the date on which the product was purchased for the first time by the end customer (invoice date). If you do not have the purchase invoice, the manufacturing date of the product registered by BCN3D Technologies will be considered as the beginning of the warranty period.

Conditions to exercise the warranty

The BCN3D warranty is granted under the following conditions:

- 1** Acquire the product through BCN3D Technologies or one of its authorized resellers (See <https://www.bcn3d.com/reseller/> to see the addresses of authorized BCN3D Distributors).
- 2** Be within the established deadlines, which are:
 - **1 year** from the invoice date for purchases within the EU.
 - **1 year** from the invoice date for purchases outside the EU.
- 3** The product must be packed in its original packaging. Otherwise, BCN3D Technologies reserves the right to accept or reject the return, or if it is estimated, a depreciation of the product.
- 4** The product has been sold as new, not as reconditioned or used.
- 5** The serial number of the product to be returned will have to correspond to the one in the BCN3D Technologies records.
- 6** Unless specifically requested by BCN3D Technologies, nothing else should be sent apart from the Product. All accessories and removable storage devices such as SD memory cards must be removed from the product. BCN3D Technologies is not responsible for the loss, damage or destruction of accessories or removable storage devices, unless caused intentionally or negligently by BCN3D Technologies.
- 7** Customers are allowed to use third-party materials, accessories, etc, since that does not cancel the warranty. As long as the use of these elements does not cause damage to the Product, the part (s) affected by this damage will be excluded from the warranty.

8 If a part of the Product is repaired or replaced during the warranty period, the remaining warranty period for the entire product will apply to this part. However, repairing and / or replacing a part will not extend the warranty period.

BCN3D Technologies official Distributors are responsible for the warranty on behalf of BCN3D Technologies. Therefore, any warranty notification must be made directly to the BCN3D Technologies official Distributor where the product was originally purchased.

Any warranty claim must first be acknowledged and accepted, either by BCN3D Technologies or by a Distributor of BCN3D Technologies. The Distributor is obliged to rectify any damage for free according to this guarantee. In the event that the defect can not be repaired, the Distributor, within the warranty period, will replace the Product for an identical product, or if the product is no longer manufactured, for a similar product of the same value or offer an adequate refund.

Depending on the country, the warranty may not automatically include the costs incurred for the shipping of the defective Products for repair or replacement.

How to exercise the warranty?

In order to exercise the warranty, you will have to contact us via <http://www.bcn3d.com/support-contact/>.

- 1** You will receive a document by email to be completed (RMA), so that we can authorize the reparation.
- 2** Once the RMA is completed, you must send it to us through the support contact form: <http://www.bcn3d.com/support-contact/>.
- 3** The technical support department will assess the situation and within 48 hours will tell you whether or not we accept your return request. If accepted, it will assign you an RMA number with a validity of 30 days.

4 The product must be sealed in its **original packaging**. In the case of not returning the order in its original and sealed packaging, BCN3D Technologies reserves the right to accept or reject the return or establish a depreciation of the product.

5 Once the product has been packed, we will send a transporter that will pick up the goods to be returned perfectly packed, being able to desist from the collection in case of improper packing. It is important that you place the **RMA number visible on the package**.

6 Once the goods are received in our facilities, our technical service will inspect them and determine whether the product is covered by warranty or not.

7 If the user does not accept the reparation, BCN3D Technologies will return the product by the agreed method of RMA. If the user does not collect the product, or if it can not be sent to the address provided by the user, BCN3D Technologies will contact the user by the means that he considers convenient and previously provided. If the user does not collect the product during the 90 days following the moment of sending the information, BCN3D Technologies reserves the right to invoice the cost of storage, disposal of the product according to the applicable laws and regulations, and any law for non-payment.

Warranty exclusions

This Warranty does not cover:

1 Defects caused by inappropriate transportation (without original packaging) or handling of the Product (including without limitation, defects caused by sharp elements, cutting, bending, compression or fall).

2 The wear and tear caused by the use of the Product, including, but not limited to, the wear of moving parts, control panels or elements that interact with the operation of the Product.

3 The damages caused by the non-compliance of the maintenance plan exposed in the User's Manual of the Product.

4 The malfunctions or damages caused by modifications, alterations or repairs carried out by any individual or company not authorized by BARCELONA THREE DIMENSIONAL PRINTERS, S.L., being excluded from this assumption the replacements of consumables.

5 Damages caused by unusual failures in the electrical network.

6 Damage caused by abuse, misuse, accident or negligence when using the Product.

7 Effects derived from the Product's exposure to floods, fire, humidity, spillage of food or chemical compounds, corrosion, oxidation, extreme atmospheric conditions or any other agent external to the Product.

8 Damages derived from the use of Software other than that recommended by BCN3D Technologies.

9 Damages caused by not using materials recommended by BCN3D Technologies.

10 The components considered as Consumables, listed in the attached document.

11 Any product in which the serial number is not visible.

Limitations and liability exemptions

This Warranty is the sole and exclusive Warranty of BARCELONA THREE DIMENSIONAL PRINTERS, S.L. and the sole and exclusive responsibility of BARCELONA THREE DIMENSIONAL PRINTERS, S.L. for the defects present in its Products. Therefore, this Warranty replaces any other guarantee issued by BARCELONA THREE DIMENSIONAL PRINTERS, S.L., whether oral or written in any method.

However, this Warranty does not limit either the consumer's rights, specified in current legislation, or the rights against the seller, also set out in the legislation.

BARCELONA THREE DIMENSIONAL PRINTERS, S.L. is not responsible in any case for the loss of business, loss of contracts, loss of profits, loss of savings, increase of costs or expenses for the use of its Products. In the same way, BARCELONA THREE DIMENSIONAL PRINTERS, S.L. rejects the responsibility of any indirect, accidental or collateral damage caused by the use of its Products.

Conformity

The BARCELONA THREE DIMENSIONAL PRINTERS, S.L. hereby declares that the BCN3D Smart Cabinet:



Complies with the essential requirements and any other applicable or required provisions of the Directives:

2014/35/UE Low Voltage Directive

2014/30/UE Electromagnetic Compatibility Directive (EMC)

2011/65/UE Restrictions on the use of hazardous substances in electrical and electronic equipment (RoHS)

2009/125/CE Ecodesign requirements for energy related products

2012/19/UE Waste electrical and electronic equipment

Conformity with the requirements of these directives is justified by the following harmonised standards:

UNE-EN IEC 61000-6-2:2019 Electromagnetic compatibility (EMC) - Part 6-2: Generic standards - Immunity standard for industrial environments

UNE-EN IEC 61000-6-4:2019 Electromagnetic compatibility (EMC) - Part 6-4: Generic standards - Emission standard for industrial environments (Endorsed by Asociación Española de Normalización in May of 2020.)

UNE-EN 61010-1:2011/A1:2020 Safety requirements for electrical equipment for measurement, control, and laboratory use - Part 1: General requirements.

Changes / modifications not approved by the responsible party could void the user's authority to operate the equipment.



This equipment has been tested and found to comply with the limits for a Class A digital device, pursuant to part 15 of the FCC Rules. These limits are designed to provide reasonable protection against harmful interference when the equipment is operated in a commercial environment. This equipment generates, uses and can radiate radio frequency energy and, if not installed and used in accordance with the instruction manual, may cause harmful interference to radio communications. Operation of this equipment in a residential area is likely to cause harmful interference in which case the user will be required to correct the interference at his own expense.

BARCELONA THREE DIMENSIONAL PRINTERS, S.L.
Carrer de Miquel Servet, 18, 08850 Gavà, Barcelona
Tel: +34 935 95 43 43
www.bcn3d.com



REI-RAEE: 6989

Specifications

| | |
|--------------------------------|---|
| PRODUCT PROPERTIES | |
| Certifications | CE/FCC |
| PHYSICAL PROPERTIES | |
| Overall dimensions | 690mm (W) x 530mm (D) x 950mm (H) |
| Weight | 85kg |
| Shipping box dimensions | 800mm (W) x 600mm (D) x 1240mm (H) |
| Shipping weight | 102kg |
| Shipping method | Half Europallet |
| ELECTRIC PROPERTIES | |
| Output | 230V / 120V / 100V |
| Input | version 230V: 200 / 208 / 220 / 230 / 240 V AC [50-60 Hz ±10Hz] version 120V: 100 / 110 / 115 / 120 / 127 V AC [50-60 Hz ±10Hz] version 100V: 100 / 110 / 115 / 120 / 127 V AC [50-60 Hz ±10Hz] |
| Power output | 1000VA |
| Data connection | USB connection (Type-A to Type-B cable) |
| UPS topology | Online 1kVA |
| Battery specifications | 3 batteries / 36 VDC x 7Ah |
| Sensor | Internal and external humidity sensor |
| DEHUMIDIFIER PROPERTIES | |
| Dehumidifier topology | Air tight container with an active humidity controller unit |
| Dehumidifier system strategy | 4-cycle desiccant and recovery system: First cycle: spool drying Second cycle: stand-by Third cycle: desiccant recovery Fourth cycle: desiccant cool-down |
| Desiccant type | Alumina base desiccant |
| Humidity level | < 40% RH |
| Recovery time (approximate) | 2h |

| MATERIAL HANDLING | |
|--------------------------|--|
| Filament diameter | 2.85mm |
| Compatible spools | <p>With BCN3D Spool Cartridge</p> <ul style="list-style-type: none"> • Diameter: 197mm - 203mm • Central bore diameter: more than 50mm <ul style="list-style-type: none"> • Width: 55mm <p>Without BCN3D Spool Cartridge:</p> <ul style="list-style-type: none"> • Diameter: up to 303mm • Central bore diameter: more than 50mm <ul style="list-style-type: none"> • Width: up to 105mm |
| Number of spools | <p>6 BCN3D Spool Cartridges</p> <p>10 small spools (350/500/750gr)</p> <p>6 medium spools (1kg)</p> <p>4 big spools (2.5kg)</p> |

Safety and compliance

General information

To avoid potential residual risks the user should read and understand the following safety measures (you are strongly advised to read this before using the machine).

To highlight the areas where extra care should be taken, safety alert stickers have been affixed to the relevant parts of the machine to warn the user of potential hazards.

Any modifications made to the machine without the manufacturer's approval will invalidate the product's Declaration of Conformity (CE) and warranty.

Consequently, the BARCELONA THREE DIMENSIONAL PRINTERS, S.L. ARE EXEMPT FROM ANY LIABILITY IF THE USER DOES NOT FOLLOW THE INSTRUCTIONS FOR USE.

Hazards

Some stickers have been affixed to the equipment to warn users about the hazardous areas, and actions which are not recommended as they will stop the system from working properly.

Supervise the system while it is working to make sure it is doing it properly.

This device is not a toy. It should not be used by minors under 16 without the supervision of an adult.

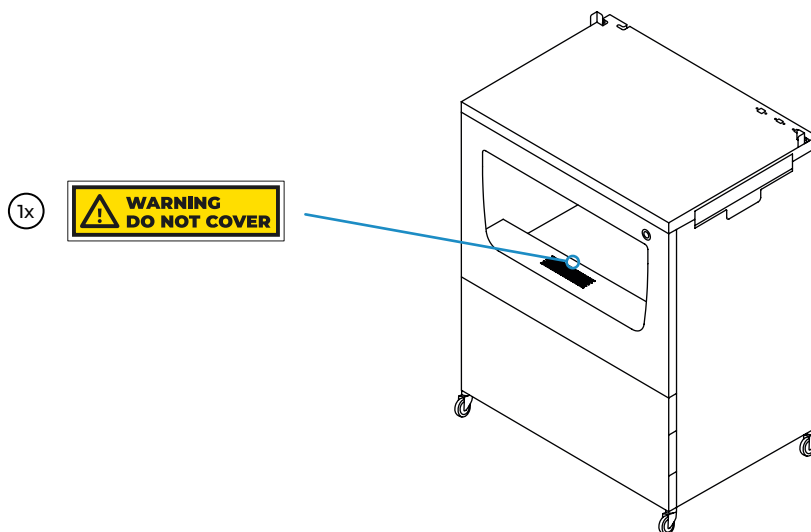

- Do not cover the air outlet of the dehumidifier. Doing so prevents the system from working properly.

Electrical safety



- As with any other appliance, do not touch the terminals of the mains, or the power source. There is a risk of electrocution. Connect the system to an electrical outlet according to the current legislation.
- Do not connect or disconnect any internal components or electrical connections while the machine is connected to a power source.
- The system is equipped with a UPS (Uninterruptible Power Supply), therefore it is possible that even when the equipment is disconnected from the wall outlet, there is still electrical current flowing through the system.
- In the event of an emergency, stop the printer immediately by pressing the switch, disconnect the power source and contact technical support to turn off the UPS.

Heating safety



- There are parts inside the dehumidifier unit that get hot during the recovery cycle. In case any maintenance operation is needed inside the dehumidifier unit, make sure that the system is disconnected from any power source and wait 15 minutes before any manipulation.

Mechanical safety



- There are few moving parts in this equipment and all of them are protected from the reach of the user. However there are some operations the user can do that can pose a pinch hazard, including: metal corners when placing the printer, dehumidifier chamber when closing the drawer or the lid, storage area when closing the door, and side tray when closing it.
- Do not put any object or part of the body between the mobile parts of the equipment.

Proper area to install the system

In order to ensure easy access to the system during normal operations and maintenance, install the machine in a place with enough space between walls and other equipment.

The distance measured from the back of the system to the wall has to be at least 200mm to allow easy access from the side. This space is important to guarantee easy access to extruders, FRS, external spools, and to prevent any damage to the back teflon tubes that go from the Smart Cabinet to the printer.

Do leave at least 800mm at the front of the unit to open the printer's door or to open the cabinet's drawer or the storage area's door.

Do not cover the unit while working in order to ensure good ventilation. Keep in mind that there are vents at each side of the cabinet and printer, so do leave some space on each side for proper ventilation.

Besides that, in order to open the dehumidifier lid (on the left) or the maintenance tray (on the right), it is recommended to leave at least 300mm of free space to the left, and 500mm of free space to the right.

Use the system at temperatures between 15 °C and 30 °C and relative humidity below 70%.

Do not forget to hit the wheels' brakes when the device is established in the final location.

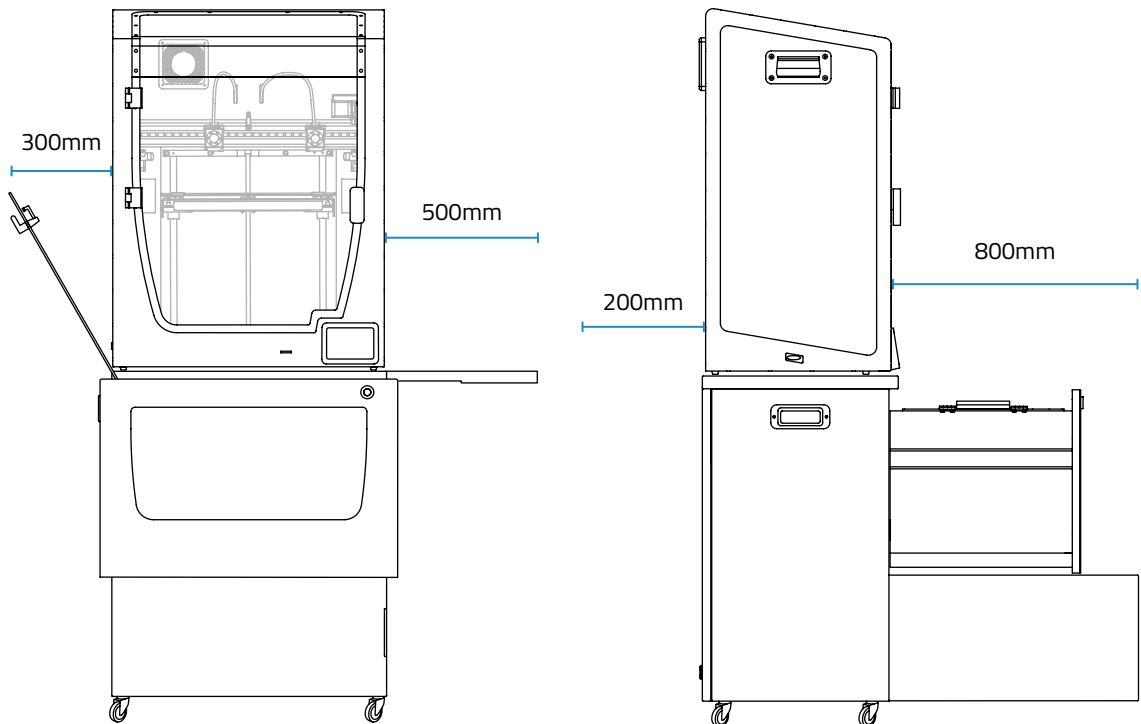

Moving the device

To ensure safe movement of the device, follow the steps described below:

- Switch off the printer.
- Disconnect the power cable that goes from the rear of the Smart Cabinet to the wall outlet.
- (If connected) Disconnect the ethernet cable that goes from the rear of the printer to the wall connector.
- Ensure that there are no moving parts inside the device that might break during transportation.
- Ensure that the printer's door, the cabinet's drawer and storage area's door are correctly closed.
- Release the brakes.
- Push or pull the system, from one side, to the final position. Use the cabinet's handle to do so.



The relocation of the device must only be performed by a person instructed in the tip-over hazards involved in this task. The whole system is heavy. Be careful and use the correct equipment at all times. Do not push the system by pushing the back of the printer, use the cabinet's side handle to pull or push the Smart Cabinet.

Installation

What is in the box?

This is the list of materials that are shipped in the box:



BCN3D Smart Cabinet

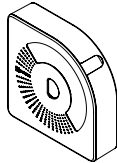

2 x BCN3D Spool Cartridge

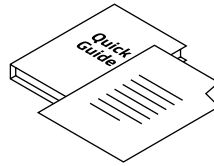

Quick Start Guide and Warranty

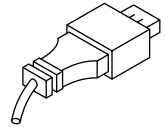

USB cable

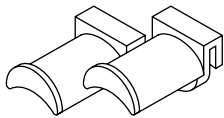

6 x Spool holder for Smart Cabinet



4 x Coupling clip

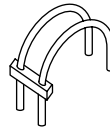

2 x Extension teflon tube for Epsilon W50

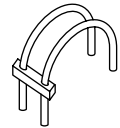

2 x Extension teflon tube for Epsilon W27/Sigma D25

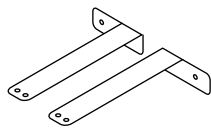

2 x Wall fixing bracket



P2 x M4 screw



2 x 5mm diameter wall screw

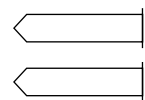

2 x Nylon wall plug

Unboxing



Watch our [video](#) to see how to correctly unbox the Smart Cabinet.



Retain packaging and pallet for warranty service.



The device is heavy and it is recommended that this step is performed by two people.

The initial indications of the unboxing are indicated on the box itself. Please follow the instructions as indicated there or read the same information here below:

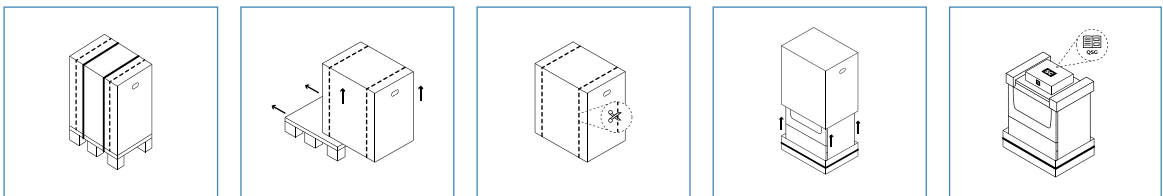

1. Remove the red pallet straps
2. Remove the pallet
3. Cut the white box straps
4. Lift the upper box
5. Open the plastic bag and read the documentation

Please follow the instructions as indicated there or read the same information here below:

1. Remove the top protective foams.
2. Cut the white strap around the bottom box (A) and pull the plastic bag all the way down.
3. Lift the unit using the side handle while another person removes this side's bottom foam and the center bottom foams (B). Gently release the device to rest on the ground.
4. Carefully pull the unit using the handle. Retire the bottom foam from the other side (C).
5. Keep pulling the unit to its final position.

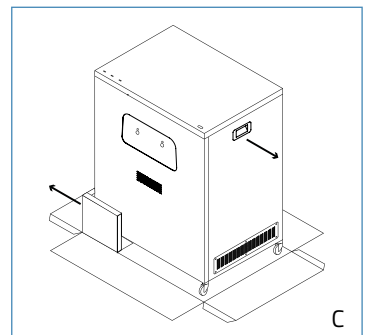
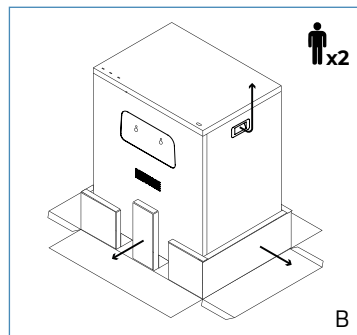
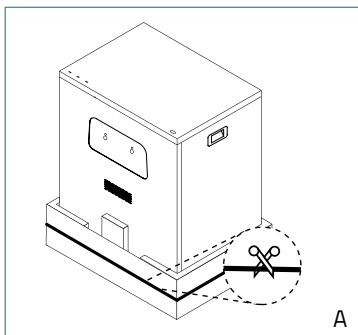

Diagram

- | | |
|---|---|
| <ol style="list-style-type: none"> 1. Dehumidifier chamber 2. Storage area 3. Maintenance tray 4. Push to open latch 5. Wheels with brakes 6. Power extension cable 7. USB Link connector 8. WiFi Dongle USB port 9. Free USB port 10. Power socket | <ol style="list-style-type: none"> 11. External outlets (for extruder 1 and 2) 12. Metal corners 13. Side handle 14. Dehumidifier unit 15. Dehumidifier chamber lid with lock handles 16. Internal outlets (for extruder 1 and 2) 17. Central pillar 18. Spool holder for Smart Cabinet |
|---|---|

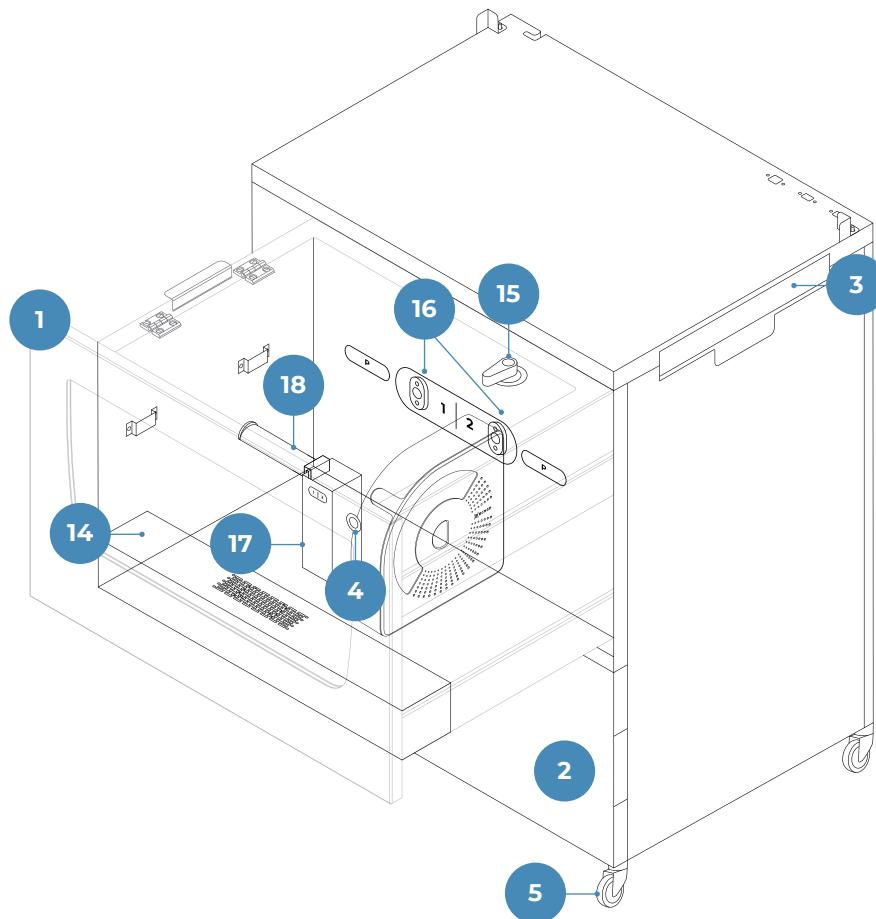

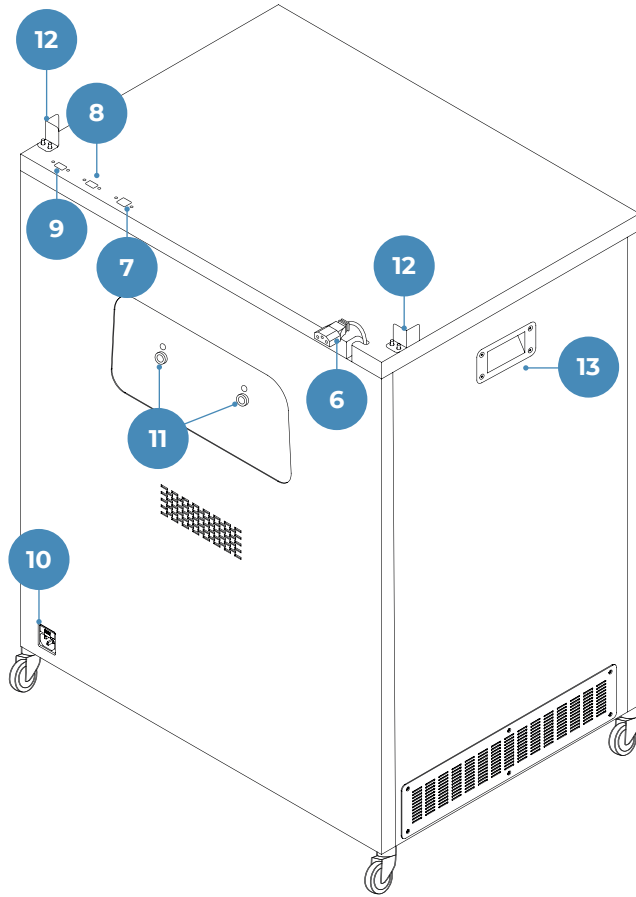

Set up

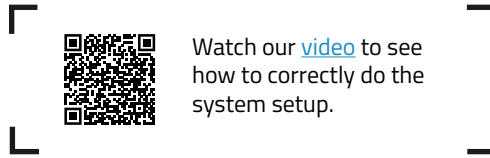

In order to ensure the safe packaging and transport of the device, some of the components are sent uninstalled. Before starting to work with the Smart Cabinet, those parts need to be installed in order to complete the setup process.

For any query while setting up the device, please refer to section [BCN3D Technical Assistance Services](#).

Follow the steps below to prepare the system:

Remove protections

Follow the instructions:

- Remove the protective film from the front cover.
- Open the drawer by pushing the push-to-open latch and pulling the door. Then remove the protective film from the lid.



Full system setup

- Unload any material loaded on the printer and turn it off.
- Unplug the power cable and keep it to use it later.
- Carefully place the BCN3D printer on top of the Smart Cabinet seated in the metal corners.
- Secure the BCN3D printer to the Smart Cabinet with the M4 screws.

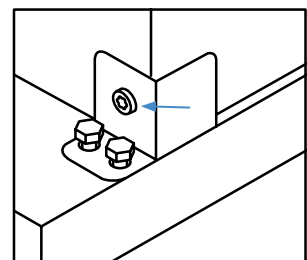



The printer is heavy and therefore this step needs to be performed by two people. Make sure that the Smart Cabinet where the printer is being installed, is close enough.

- On the back, take out the teflon tubes from the FRS quick connector (D.1).
- Take the correct set of extension teflon tubes from the upper foam.



There are two sets, one suitable for Epsilon W50 and another for Epsilon W27/Sigma D25. Use the ones that adapt to your printer.

- Using the plastic bridge as reference, connect the short side of the extension teflon tubes to the external outlets on the Smart Cabinet and the long side to the FRS inlet connector (D.2).
- Secure the teflon tubes with the coupling clips on the four ends.



Remember that these steps would cancel the possibility to insert the filament from inside the printer. From now on, the printer is fed with filament coming from the Smart Cabinet.

- If installed on the printer, remove the USB Wifi Dongle and connect it to the "WiFi" port (E).
- Connect the USB Link cable: the USB Type B end of the cable is connected to the "CONN" port while the USB Type A end of the cable is connected to the printer (E).
- Plug the printer with the power extension cable.
- Use the power cable that comes with the printer to plug in the Smart Cabinet. The other end of the cable is connected to a power outlet.



At this point, the lights of the Smart Cabinet turn on. The Smart Cabinet stays always ON when power is supplied, allowing the dehumidifier to continuously control humidity.

- Remove the metal corners and use the same screws to attach the wall fixing brackets to them as indicated in the picture.

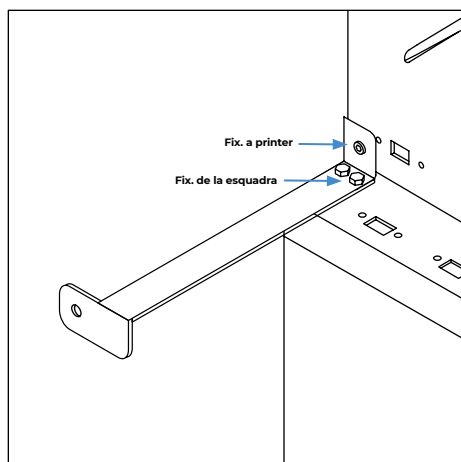

- Make holes on the wall at the distance indicated in the drawing.

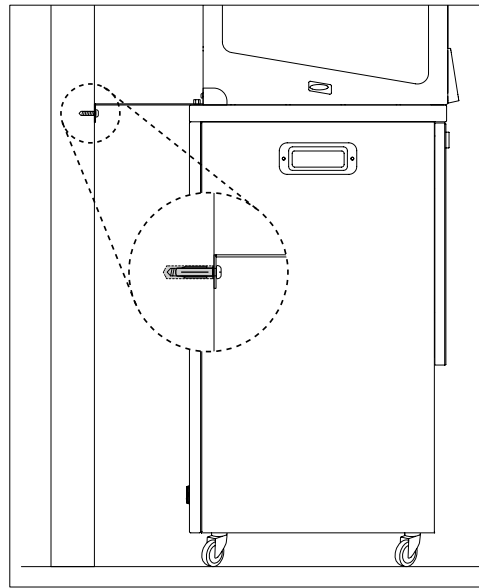
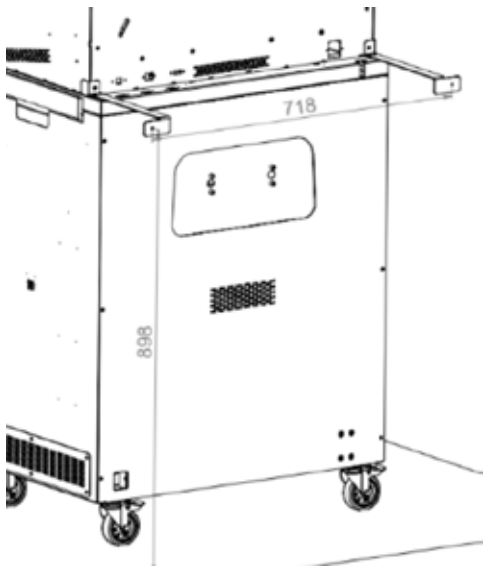

- Insert the nylon plugs in the holes and use the 5 mm diameter wall screws to attach the device to the wall with the wall fixing brackets.
- Use the brakes to hold the device in place.
- Turn on the printer.

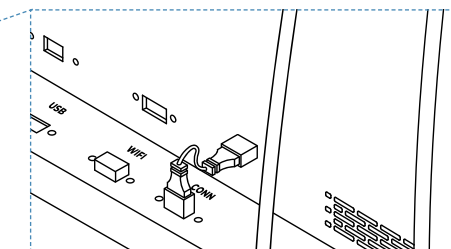
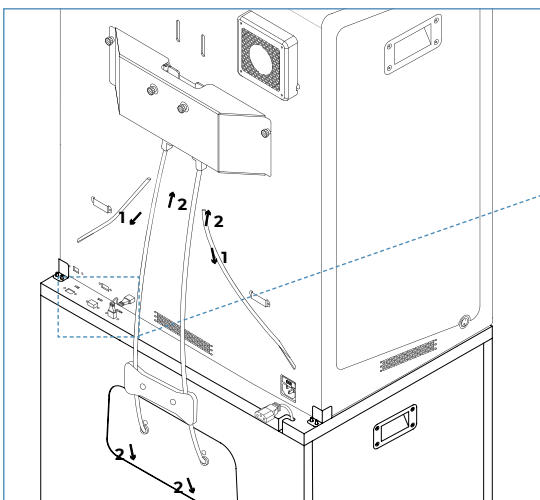

D

E

Getting started

Once the unit is correctly installed with the printer connected to it, it is time to proceed with the preparation protocols. These protocols include storing the filament spools, the tools and other items.

Store material spools inside the dehumidifier



The Smart Cabinet continuously controls the humidity inside the chamber. For this reason, do not leave the lid open for long periods of time and be sure the lock handles are always in the closed position as indicated on the picture:

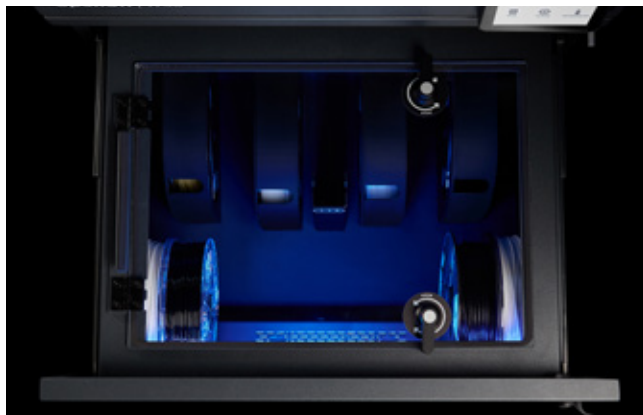

Keeping the chamber completely sealed will increase the performance of the dehumidifier and the filaments will keep better conditions for printing. For more information about how it works, check the [Humidity control](#) section.

There are many possible combinations for storing spools inside the dehumidifier unit. Our recommendation is to use the BCN3D Spool Cartridge when possible.

Using BCN3D Spool Cartridges

Using the BCN3D Spool Cartridge to store and place the filament spools is highly recommended. It helps keep correct rotation of the spool when printing and it helps contain the filament slack after performing an [unload operation](#).



The BCN3D Spool Cartridge is compatible with all the BCN3D Filaments 500gr and 750gr. spools, as well as a wide variety of spools from third-party material manufacturers. Spools with the following dimensions are compatible:

Diameter (d1): up to 203mm

Central bore diameter (d2): more than 50mm

Width (w): 55mm

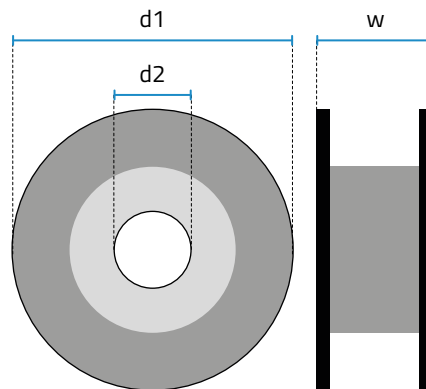

If using non compatible spools, check the information about loading spools [without BCN3D Spool Cartridges](#).

This is the recommended distribution of cartridges in the dehumidifier:

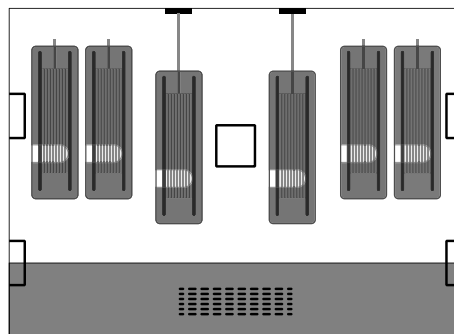

- Take out the two BCN3D Spool Cartridges that are stored in boxes in the dehumidifier chamber.



The spool holders are also stored in these boxes, but they are only needed for spools without the BCN3D Spool Cartridge.

- Take one of the cartridges and perform the same operation for the other:

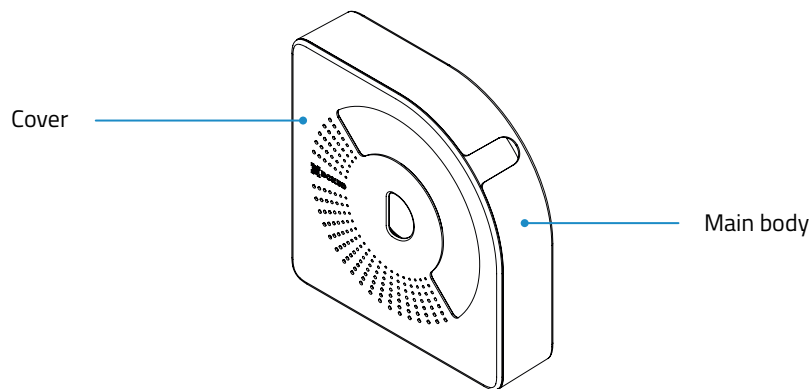

- Separate the two parts: the Main body and the Cover.
 - Insert the central bore of the spool in the Main body.
 - Take the end of the filament and insert it through the filament outlet.
 - Close the cartridge with the cover. The magnets will automatically hold both parts together with the spool inside.
- Place up to 6 cartridges, one aligned with each other. Take into account that the two center positions are used to load filament to the printer, as indicated in the labels, one for the left extruder (1) and one for the right extruder (2).



Another possible distribution of the spools is the following, depending on how many cartridges are placed inside:

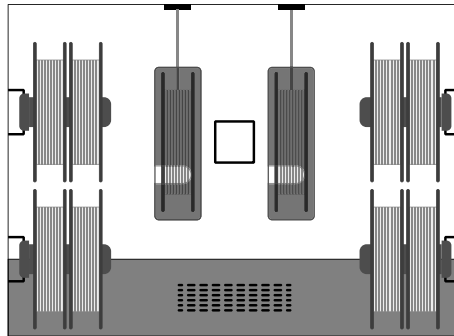

Without BCN3D Spool Cartridges

When not using the BCN3D Spool Cartridge, it is still possible to fit the spools in the dehumidifier and print, using spool holders to hang the spools.



There are filaments on the market that are coiled in narrower (350gr.), wider (1kg.) or bigger (2.5kg.) reels compared with the default sizes indicated above. These spools are also supported to fit inside the dehumidifier but only if they fulfill the following requirements:

- Diameter (d1): up to 303mm
- Central bore diameter (d2): more than 50mm
- Width (w): up to 105mm



Not using the BCN3D Spool Cartridge may produce excess slack in the filament while performing an [unload operation](#).

Here there are several possibilities to store different types of spools:

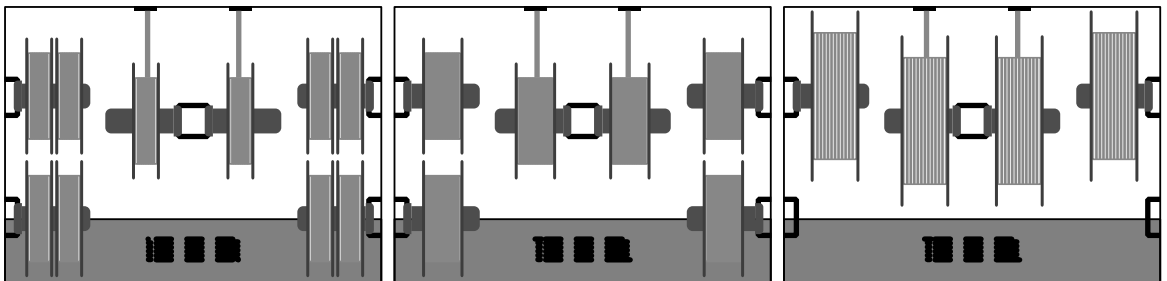

Layout with default spools (500 or 750gr.): up to 10

Layout with wider spools (1kg.): up to 6

Layout with big spools (2.5kg.): up to 4

- Take as many spool holders as you need from the boxes stored in the dehumidifier chamber (there are 6 in total).
- Hang the spools in the spool holders and place them afterwards in the holders as indicated in the images above, depending on your needs.



Take into account that for some specific combinations, removing the spool holder together with the spool is needed, due to space optimization.

Store tools in the maintenance tray

The Smart Cabinet includes a maintenance tray where the tools provided with the printer can be stored and kept always ready for maintenance.

In order to store the tools, follow the instructions:

- Take the tools from the toolkit pack that comes with the printer.
- Open the maintenance tray.
- Carefully place the tools on the space designated for each one.



Store consumables in storage area

The storage area is the area on the bottom of the unit. It is prepared to store anything that may be needed. The recommendation is to store consumables and spare parts for the printer, so that they are always close enough for the daily operation.



The area has the following dimensions:

Width: 650 mm.

Height: 250 mm.

Depth: 450 mm.

In this space you can fit for instance:

- Up to 18 small BCN3D Filament's boxes.
- Up to 4 big BCN3D Filament's boxes.
- Glass build plates.
- Hotends.

Material handling

Load filament

Loading the filament from inside the dehumidifying unit is very easy. The spools that are in use must be stored in the *Loading area*, using the left space to hang the spool that goes to the extruder (1) (left) and the right space to hang the spools that goes to the extruder (2) (right).



Using BCN3D Spool Cartridges

If using the BCN3D Spool Cartridge, insert the spool into the cartridge as indicated in the instructions that can be found on the box. After this operation, the spool must be inside and one end of the filament coming out from the front hole as in the image.



Follow the instructions:

- Open the dehumidifier chamber's drawer and lid.
- If present, remove any material spool.
- Select *Filament > Load* on the printer's screen and select the extruder and the material type.
- While the hotend is heating up, place the cartridge flat in the loading area with one hand and with the other hand, take the loose end of the filament.



- Insert the filament into the internal outlet. Keep pushing until the printer detects the presence of filament on the extruder.
- Slide the cartridge to the back until you hear an audible "snap", meaning that the magnets have caught each other, preventing the cartridge from moving.
- Follow the instructions on the screen.

Without BCN3D Spool Cartridges

If not using the BCN3D Spool Cartridge, follow these instructions:

- Open the dehumidifier chamber's drawer and lid.
- If present, remove any material spool.
- Select *Filament > Load* on the printer's screen and select the extruder and the material type.
- While the hotend is heating up, hold the spool on the spool holder that is in the corresponding loading area (if there is no spool holder, take one from the accessories and place it on the central pillar).



- Take the loose end of the filament and insert it into the internal outlet.



- Keep pushing until the printer detects the presence of filament on the extruder.
- Follow the instructions on the screen.

Unload filament

Unloading is performed when there is the need to change the material type or when the spool is finished and another spool must be used to replace it.

If using the BCN3D Spool Cartridge, the unloading process is more controlled since the filament always remains inside the cartridge even when there is a lot of slack after the unloading.

Using BCN3D Spool Cartridges

Follow the instructions:

- Select *Filament > Unload* on the printer's screen and select the extruder. As soon as the hotend reaches the temperature, the extruder will automatically move the filament backwards.
- Once the extruder finishes moving the filament, open the dehumidifier chamber's drawer and lid.
- Take the BCN3D Spool Cartridge with one hand and pull to unattach the magnets. With the other hand, grab the filament and pull to take it out from the dehumidifier.
- Close the lid using the lockers to keep an air tight chamber. Then close the drawer.



If there is enough filament to use again, you can rewind the extra filament using the side holes dedicated to it.



Without BCN3D Spool Cartridges

Follow the instructions:

- Select *Filament* > *Unload* on the printer's screen and select the extruder. As soon as the hotend reaches the temperature, the extruder will automatically move the filament backwards.
- Once the extruder finishes moving the filament, open the dehumidifier chamber's drawer and lid.
- Rewind the spool with one hand. With the other hand, grab the filament to prevent knots
- Keep rewinding until the filament comes out of the internal outlet.
- Take the spool out of the dehumidifier. Take the spool holder out if needed.
- Close the lid using the lockers to keep an air tight chamber. Then close the drawer.

Humidity control

Supported by our smart drying technology, the humidity-controlled environment has been designed to extend the service life of your materials, protecting the filament and reducing print failure due to moisture, significantly improving your prints' quality.

An automatic drying cycle pushes the air through a compartment filled with alumina, a material that absorbs the moisture. The desaturated air is pushed back towards the material compartment, free of any moisture that could damage your filaments. This cycle significantly reduces the environment's relative humidity. This technology effectively keeps the filament dry, ensuring that the materials maintain their mechanical properties throughout the whole 3D printing process.

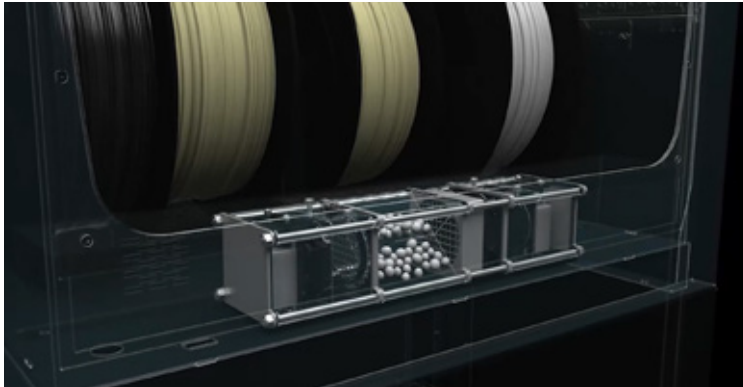

The dehumidifier ensures that the air tight chamber never exceeds 40% of relative humidity at any time, when the unit is used under the recommended environment conditions. Lower values of relative humidity inside the chamber can be reached when the external humidity conditions are not so high.

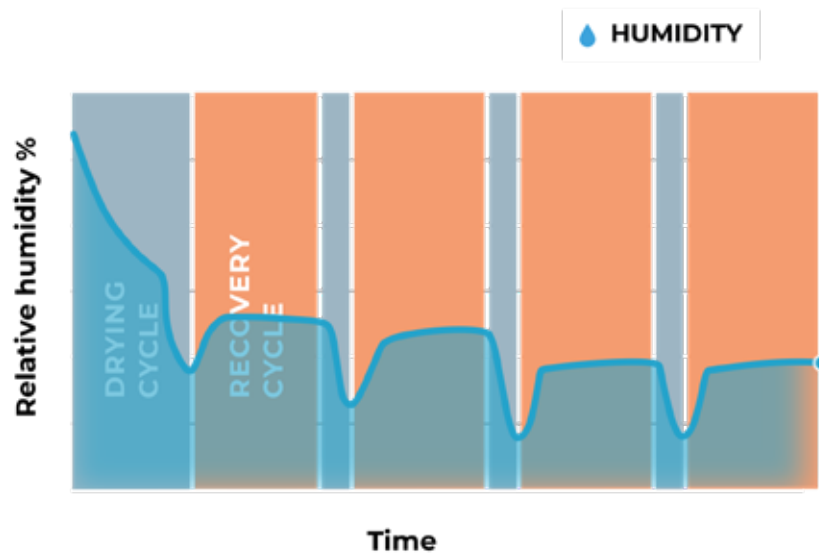

The dehumidifier regenerates the alumina only if power is supplied, therefore the humidity levels inside the chamber might not be optimal if the Smart Cabinet is not plugged in for a long period of time.

Power protection

The built-in Uninterruptible Power Supply (UPS) filters the electric signal and protects the printer from any possible outages and micro-cuts on the electric current.

There are different scenarios:

- In the event of a blackout, the printer will turn into “battery mode” and keep printing for about **30 seconds**.
- If the duration of the outage is longer, the printer will pause the print job (moving the print heads to the home position) and **store the last printing position**.



- The printer will stay awake while there is enough battery. The duration of the full battery is typically **around 10 minutes**. When the power is back before the battery runs out, the printer will **automatically resume the printing process**.



This time may vary on every unit and it depends on the battery levels and the power consumption. If, for any reason, the battery level on the UPS is very low or the power consumption is very high, this time may be less.

- In case of a longer outage, the user is prompted to **manually resume the printing process** after it's checked that there is no consequence to continue printing.

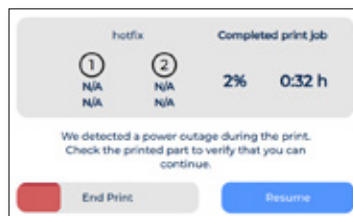

Maintenance

Maintenance is a very important work to keep in mind every day in order to keep the system in good condition and always performing at its maximum capabilities.

The following information shows which activities have to be carried out to give the BCN3D Smart Cabinet the proper maintenance and their frequency. Maintenance activities do not take much time and are not complicated. However, for those that need more attention, more detailed guidelines are provided to guide you through the process.

General maintenance

In general, there are some recommendations when performing general maintenance, but there are some indications that you must always consider in order to extend product life.

A very important advice is to keep your system always free of dust and operating in a dry and cool place. We suggest that the system operates in an environment at temperatures between 15 °C and 30 °C and relative humidity below 70%.

Regarding the filaments, we advise that the spools that are not currently in use are always stored inside the dehumidifier chamber, that keeps a controlled environment with relative humidity below 40%.

| Activity | Frequency | Tools |
|---|--|-------------------------|
| Keep the system clean | When necessary | Cloth |
| Keep the drawer's sealing clean | When necessary | Cloth |
| Keep the interior of the dehumidifier chamber clean | When necessary (keep in mind that it's not recommended to open the chamber if not needed, in order to keep good humidity conditions) | Cloth Vacuum cleaner |
| Keep the wheels clean | When necessary | Cloth |
| Check wheels' brakes | Monthly | - |
| Check good conditions of teflon tubes | Monthly | - |
| Lubricate linear guides of the dehumidifier unit | Quarterly | Grease |
| Lubricate linear guides of the maintenance tray | Quarterly | Grease |

Firmware upgrade

At BCN3D we want you to have a great experience, and to achieve this we are continually working to create new software upgrades for our products.

To ensure that your system is equipped with the latest features it is recommended to keep the software updated to the latest version.

Over-the-air updates are shown on the printer's screen to notify when a new version is available, only when the printer is connected to the network. Doing it manually is also possible: visit the [Knowledge Base](#) and follow the instructions.

Troubleshooting

The [Knowledge Base Troubleshooting](#) includes a list of processes to try to fix the most common issues that might occur.

If you do not find a solution to your problem in this section, please contact the BCN3D Technologies support team through [Contact Support](#).

Error message

Error message is a list of errors that the BCN3D Smart Cabinet can show on the printer's screen to isolate the specific cause or causes of the symptom. The symptom is a failure of some process to produce any results.

If you identify some of these error messages, make sure to check the [Knowledge Base Error List](#) first. If the problem persists, please visit [Contact Support](#) in order to solve it.

| Error message | Description |
|--|---|
| Humidity level inside the chamber above accepted threshold | This error occurs when the average humidity level inside the dehumidifier chamber in the last 2 hours exceeds the maximum allowed value: 40%. The recommendation is to check if the chamber is correctly closed and sealed. If the error does not recover in the next 2 hours, then contact the BCN3D Technologies Technical Assistance Services. |
| Firmware flashing error | This error can appear when the printer failed to successfully upload the firmware from embedded electronics to the Smart Cabinet's mainboard. This error is caused by a faulty connection or the printer has been turned off during the process. |
| Lost connection with UPS | This error can appear for unknown reasons or because the printer was turned on before the USB link cable was connected. To workaround this problem, connect the USB link cable before turning on the printer or, if the cable is already connected, reboot the printer. |
| Unknown Error | The BCN3D Printer has encountered an unknown error. Unfortunately, we do not know the cause of this error. Please contact BCN3D Technologies Technical Assistance Services by raising a support request above. |

BCN3D Technical Assistance Services

Technical Assistance

You can contact the technical assistance services using the form in the Knowledge Base, and we will answer you as quickly as possible: <http://www.bcn3d.com/support-contact/>

Email

If you have a question that is not related to technical assistance, please send us an email to the address below. A BCN3D Technologies expert will contact you as quickly as possible: info@bcn3d.com

You can find all of this information in the Contact Section of our website: <https://www.bcn3d.com/contact-us/>

Be sure to include the serial number of your printer whenever you send us a query to help us provide the best possible services.



If you do not find a solution to your problem in this manual, please contact the BCN3D Technologies support team through [Contact Support](#)

Terms and conditions

Overall Vision

The terms “we”, “us” and “our” refer to BCN3D Technologies. The terms “you” and “your” refer to the person or entities that purchase any service or product. BCN3D Technologies offers all the information about products, tools, and services available, always conditioned to the acceptance of all the terms, conditions, policies and notices that are specified below. By purchasing one of our products, you will be accepting our terms and conditions, including the additional terms and conditions and the policies mentioned in this document.

Return policy

BCN3D accepts returns for refunds or exchanges, subject to the following:

1 Withdrawal right

You have 14 days from the date of reception of the product to execute the right of withdrawal. In order to request a return, the product must not have been opened, it should be closed and sealed inside its original box. If you have opened the product, it will not be eligible for a refund. This said, the transport costs (both shipping and return, in addition to possible customs fees if the merchandise comes from outside the European Union) will be responsible of the customer and deducted from the amount to be returned.

Requirements:

- Having acquired the product through **BCN3D Technologies**
- Be within the established deadline, **which is 14 calendar days from the reception** of the order.

2 Defective goods

If you detect any defect in the operation of the product, you have 7 working days from the reception of the product to communicate this defect and proceed to its return.

You should contact the support department through <http://www.bcn3d.com/support-contact/>, to notify of this incident.

In this case, BCN3D Technologies will be responsible for all the transportation costs.

In cases of wear or tear of the product due to causes that are not exclusively of its use, BCN3D Technologies reserves the right to accept or reject the return of the product, in addition to establishing the conditions of such return or substitution of the product.

3 The product received has been damaged during transport

The client will have 24 hours to verify and communicate the integrity of all the components of the order and verify that all the pertinent goods are included within the total set of the demanded product. An order will be considered delivered when the delivery receipt is signed by the customer.

Upon receiving the goods, you must ensure the external package is in good conditions and shows no symptoms of having received a blow. If the package has any sign of having received a blow or any other damage, you must reject it, reflecting it on the delivery note of the carrier and notifying the support department by email (support@bcn3d.com) during the following 24h.

How to make a return?

In order to make a return, first you will have to contact us using the contact form in <http://www.bcn3d.com/support-contact>, explaining the reason for your willingness to return or substitute one or more products.

- You will receive a document by email to be completed (RMA), so that we can authorize the return.
 - Once the RMA is completed, you must send it to us through the support contact form: <http://www.bcn3d.com/support-contact>.
 - The after-sales department will assess the situation and within 48 hours will tell you whether or not we accept your return request. If accepted, it will assign you an RMA number with a validity of 30 days.
 - The product must be sealed in its **original packaging**. In the case of not returning the order in its original and sealed packaging, BCN3D Technologies reserves the right to accept or reject the return or establish a depreciation of the product.
 - Once the product has been packed, we will send a transporter that will pick up the goods to be returned perfectly packed, being able to desist from the collection in case of improper packing. It is important that you place the **RMA number visible on the package**.
 - You will not have to pay anything to the courier, except if the withdrawal right is applied (first case), where the cost of the carriage will be deducted from the amount to be returned; or in case the damages produced in the products are not caused by the transport or are not a manufacture defect. In all these scenarios the customer will be responsible for the shipping costs.
- Once the goods are received in our facilities, our technical service will inspect them and determine whether the return is accepted or not.
 - The refunds will be carry out between the 1st and 10th of the month according the return acceptance. For example, if the return becomes effective on April 15, the money will be paid between May 1 and May 10.
 - In case of not accepting the return for damages produced outside BCN3D Technologies responsibility, you will be given the option to repair the product or return it as it is. Both the repair and shipping will be borne by the customer.

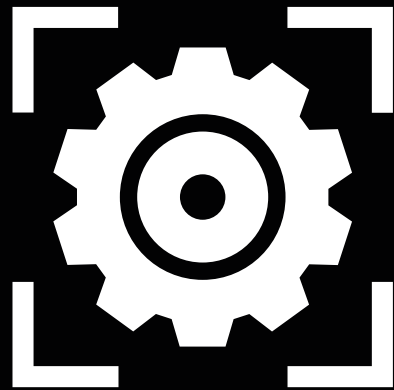

BCN3D